

78 Vega Street, Revesby

Endless Potential on a Level Approx. 1,056sqm Block - Move In, Invest or Develop - 16 Min Walk to Revesby Station

SOLD PRIOR TO AUCTION

Positioned on a generous, level approx. 1,056sqm parcel with a 15.23m frontage, this single-storey home presents a superb opportunity for families, investors and developers alike. Offering duplex site potential (STCA) and scope to add granny flats at the rear, the possibilities here are as exciting as they are versatile. Move straight in, lease out immediately, or plan possibilities for the future.

The current home is well-maintained and thoughtfully laid out, featuring four bedrooms plus an additional home office or rumpus space, ideal for growing families or those working from home. Multiple living areas, including separate lounge and dining zones, provide flexibility for everyday living, while the covered outdoor entertaining area creates a relaxed space to enjoy year-round.

Designed for practicality, the home also caters to tradespeople with

All information contained therein is gathered from relevant third parties sources. We cannot guarantee or give any warranty about the information provided. Interested parties must rely solely on their own enquiries.

4 1 5

FOR SALE
\$2,200,000

AGENTS

Lush Pillay
0407 121 573
lush.pillay@ljhooker.com.au

Baker Chahwan
02 9771 1177
baker.chahwan@ljhooker.com.au

AGENCY

LJ Hooker Padstow
(02) 9771 1177

LJ Hooker

side access and a secure gate providing ample off-street parking, plus an additional double tandem garage complete with workshop and a separate storage room and shed. Conveniently located close to local shops, schools, parks and public transport and just a 16-minute walk to Revesby train station with express CBD and airport links, this home combines convenience and long-term potential in a tightly held, peaceful pocket of Revesby.

- Duplex site & granny flat potential set on approx. 1,056sqm w/ 15.23m frontage (STCA)
- Single storey home with four bedrooms plus additional office or rumpus retreat
- Multiple living & dining zones & covered BBQ entertaining area w/ separate toilet
- Strong land banking opportunity w/ capital upside, lease out now while you plan
- Double garage w/ workshop & additional storage room, side access with secure gate
- Exceptional scope to build your dream home, renovate or add granny flats (STCA)
- Convenient access to m5 motorway, shops & schools just a short walk away
- 16-minute walk to Revesby Station with express CBD and airport direct links

Disclaimer: All information contained herein is gathered from sources we believe reliable. We have no reason to doubt its accuracy, however we cannot guarantee it. All interested parties should make and rely upon their own enquiries.

MORE DETAILS

Property ID	1EX1FAE
Property Type	House
Land Area	1056 m2
Including	Air Conditioning Built-in-Robes Car Parking - Surface Close to Schools Close to Shops Close to Transport Security Access

Lush Pillay 0407 121 573

Principal & Director | lush.pillay@ljhooker.com.au

Baker Chahwan 02 9771 1177

New Business Associate & Sales | baker.chahwan@ljhooker.com.au

LJ Hooker Padstow (02) 9771 1177

2 Padstow Parade, PADSTOW NSW 2211

padstow.ljhooker.com.au | reception.padstow@ljhooker.com.au

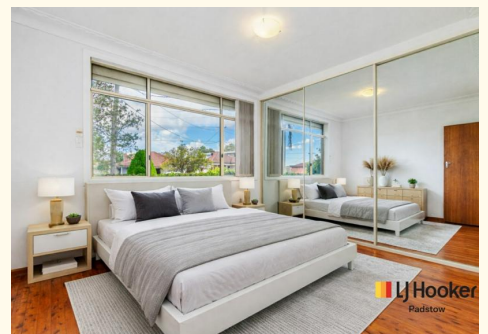

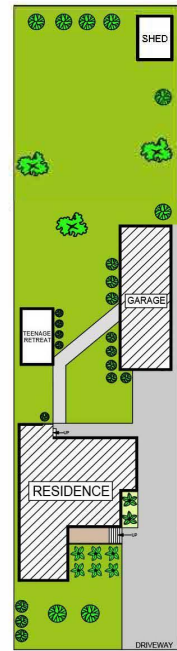
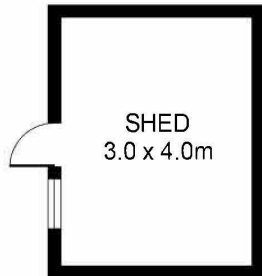

SITE PLAN

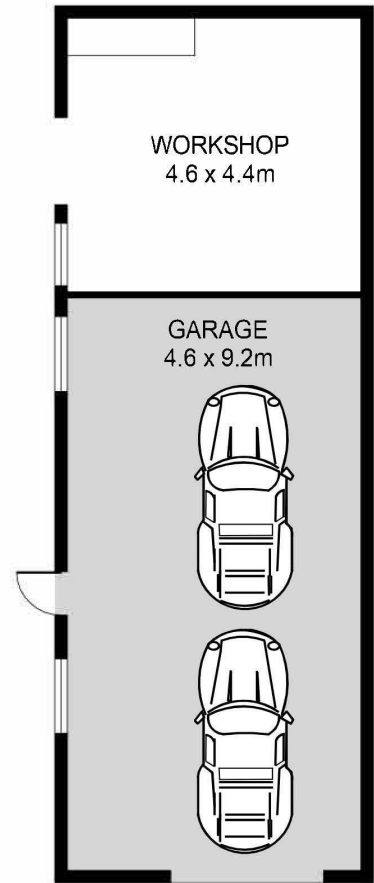
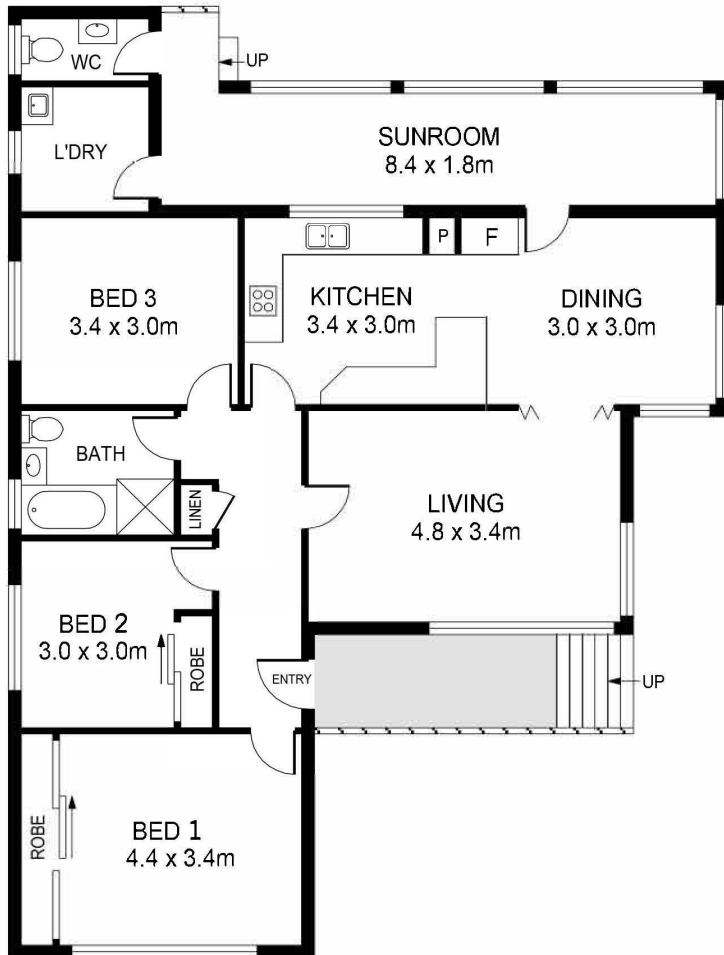

78 VEGA STREET, REVESBY

DISCLAIMER:

PLANS SHOWN ARE FOR MARKETING PURPOSES ONLY, ALL DIMENSIONS ARE APPROXIMATE AND NOT TO SCALE. THEY ARE SUBJECT TO ERRORS AND INACCURACIES AND NO LIABILITY WILL BE ACCEPTED. INTERESTED PARTIES SHOULD MAKE THEIR OWN INQUIRIES.

PLANS BY PROPERTY INTELLIGENCE MEDIA 1300 20 30 38

 **LJ Hooker**
Padstow

All information contained therein is gathered from relevant third parties sources. We cannot guarantee or give any warranty about the information provided. Interested parties must rely solely on their own enquiries.

 **LJ Hooker**