



8/40-50 Union Road, Penrith



CENTRAL PENRITH OPPORTUNITY

Positioned at the rear of a sought-after complex, this like new apartment offers the perfect blend of privacy, modern comfort, and convenience. Designed with an adaptable floorplan, it creates a wonderful sense of space, with a sleek stone-appointed kitchen seamlessly flowing into the open-plan living and dining area. From here, sliding doors open onto a generous private balcony, ideal for entertaining or simply enjoying a quiet moment.

The apartment features two spacious bedrooms with built-in wardrobes, including a main bedroom with its own ensuite, as well as a stylish central bathroom. Added comforts include split-system air conditioning, intercom entry, a secure car space, and a handy storage cage.

Perfectly positioned in the heart of Penrith, you'll be just 350 metres from Westfield Penrith and only 750 metres from Penrith Train Station. Surrounded by schools, shopping centres, parks, and the Penrith Panthers Leagues Club, this apartment places everything you need at your doorstep.

Offering a low-maintenance lifestyle with every convenience, this is an

2  2  1 

FOR SALE

Please Call

AGENTS

Tony Liras

0425 269 611

tliras.penrith@ljhooker.com.au

AGENCY

LJ Hooker Penrith

(02) 4732 2322

All information contained therein is gathered from relevant third parties sources.
We cannot guarantee or give any warranty about the information provided.
Interested parties must rely solely on their own enquiries.

 **LJ Hooker**

outstanding opportunity for first home buyers, investors, or downsizers alike.

This is an opportunity not to be missed.

Disclaimer: Information contained in this document/advertisement has been provided by third party organisations including NSW State Government, Corelogic and REA. Budsip Pty Ltd T/A LJ Hooker Penrith does not make any warranty or offer any guarantee as to the accuracy, completeness or reliability of the information or accept any liability arising in any way from any omission or error whatsoever within the information provided. The information should not be regarded as advice or relied upon by you or any other person and Budsip Pty Ltd recommends that you seek professional advice before making any property decisions.

MORE DETAILS

Property ID	1QTJF70
Property Type	Apartment
Including	Air Conditioning

Tony Liras 0425 269 611

Licensed Real Estate Agent, Auctioneer |
tliras.penrith@ljhooker.com.au

LJ Hooker Penrith (02) 4732 2322

2/314 High Street, PENRITH NSW 2750
penrith.ljhooker.com.au | penrith@ljhooker.com.au

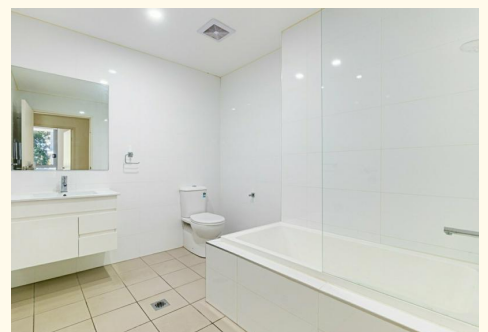

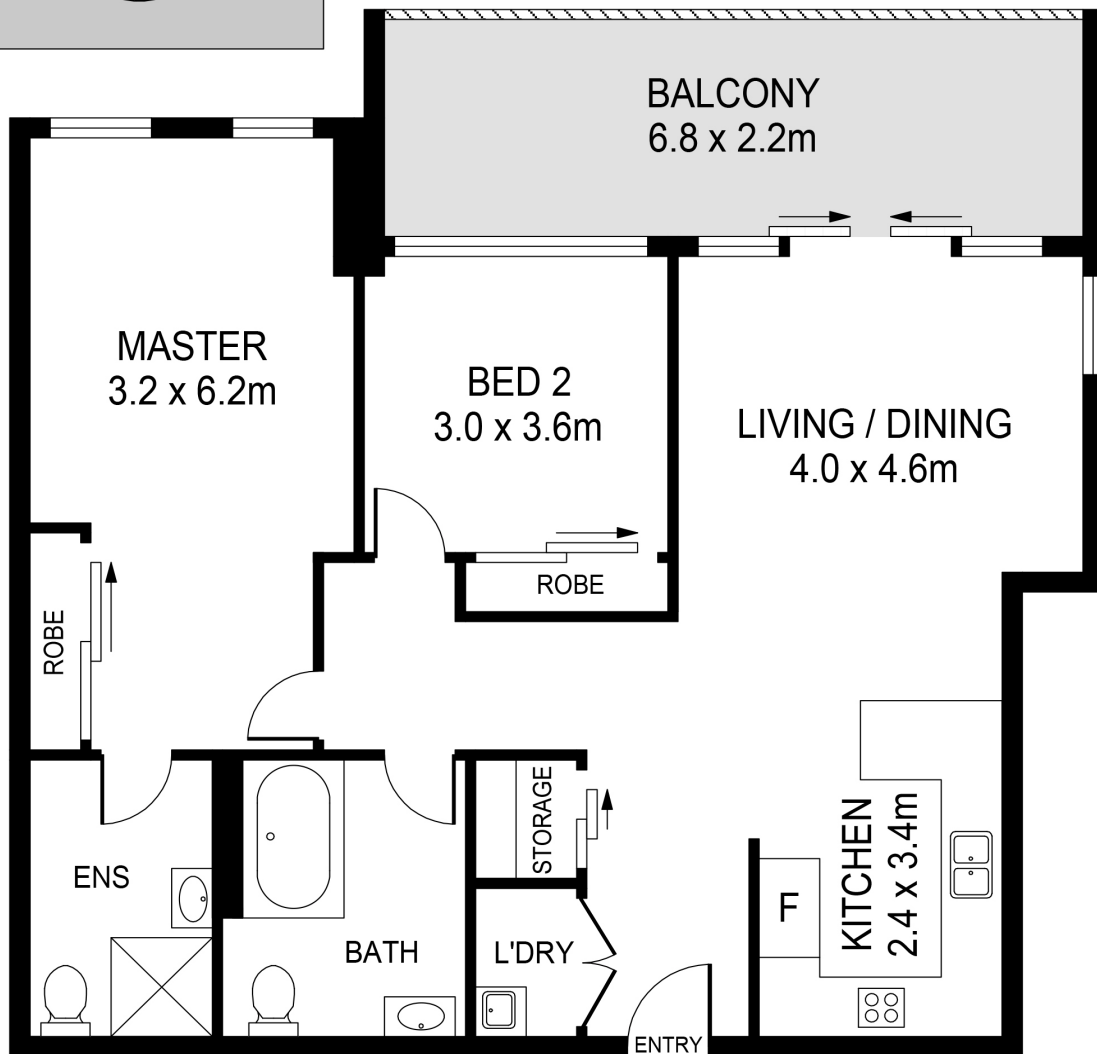
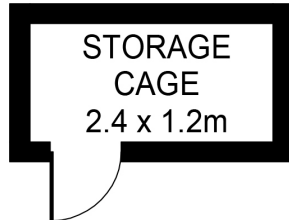
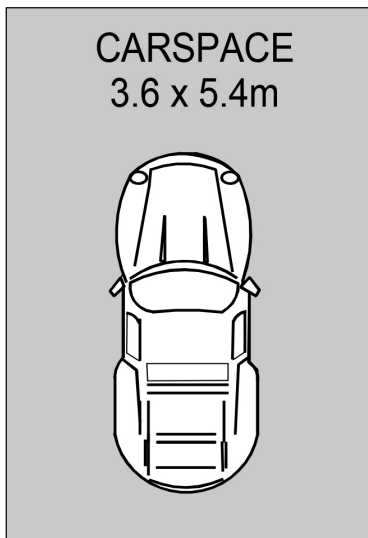

8/40-50 UNION STREET, PENRITH

DISCLAIMER:

PLANS SHOWN ARE FOR MARKETING PURPOSES ONLY. ALL DIMENSIONS ARE APPROXIMATE AND NOT TO SCALE. THEY ARE SUBJECT TO ERRORS AND INACCURACIES AND NO LIABILITY WILL BE ACCEPTED. INTERESTED PARTIES SHOULD MAKE THEIR OWN INQUIRIES.



All information contained therein is gathered from relevant third parties sources. We cannot guarantee or give any warranty about the information provided. Interested parties must rely solely on their own enquiries.

