



4/17 Adah Street, Guildford

Modern Spacious 3 bedroom Town House

Positioned in a boutique complex of only five townhouses, this well-designed tri-level residence offers generous space, multiple outdoor areas, and secure comfortable. Perfect fit for your first home buyers if your seeking comfort, practical floor pan, and low-maintenance living.

Features

- 3 spacious bedrooms, all with built-in wardrobes
- Master bedroom with ensuite and additional storage closet
- Main bathroom with combined shower and bath
- Gas kitchen with ample cupboard space and storage
- Open-plan living and dining area filled with natural light
- Ducted air-conditioning throughout the entire home
- Ground-level laundry with additional toilet for convenience
- Front courtyard with sunshade and private rear courtyard with pergola
- Secure basement level with double lock-up garage with internal access from basement directly into the home
- Only five townhouses in the complex, offering privacy with an Intercom system for added security

Location Highlights

All information contained therein is gathered from relevant third parties sources. We cannot guarantee or give any warranty about the information provided. Interested parties must rely solely on their own enquiries.

3 2 2

FOR SALE
\$968,000

AGENTS

Soon Tee
0420 966 377
Soon.Tee@ljhooker.com.au

Ronica Leung
0451 373 888
ronica.leung@ljhooker.com.au

AGENCY

LJ Hooker Parramatta | Granville |
Guildford | Merrylands
(02) 9637 8555

LJ Hooker

- Short walk to Guildford Train Station with direct trains to Parramatta and Sydney CBD
- Around 5 minutes' drive to Granville Train Station and just one stop to Parramatta Train Station
- Approximately 15 minutes' drive to Westfield Parramatta
- Close to local shops and eateries along Guildford Road village strip
- Easy access to Woodville Road and M4 Motorway for convenient commuting
- Surrounded by local parks, schools, and community facilities

Strata \$830pq approx. Water \$215pq approx Council \$393pq
Total 230sqm and living 144sqm

Contact the team for more information or inspection.

MORE DETAILS

Property ID 2GUKF9E
Property Type Townhouse

Soon Tee 0420 966 377

Area Specialist | Soon.Tee@ljhooker.com.au

Ronica Leung 0451 373 888

Sales Associate to Soon Tee | ronica.leung@ljhooker.com.au

LJ Hooker Parramatta | Granville | Guildford | Merrylands (02) 9637 8555

42 South Street, GRANVILLE NSW 2142

granville.ljhooker.com.au | granville@ljhooker.com.au

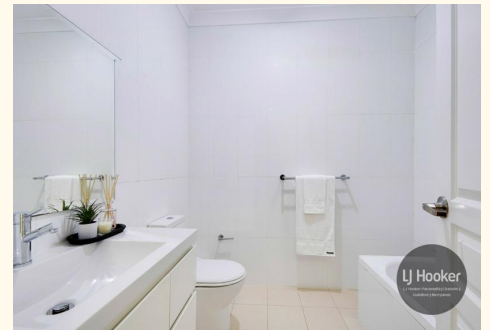

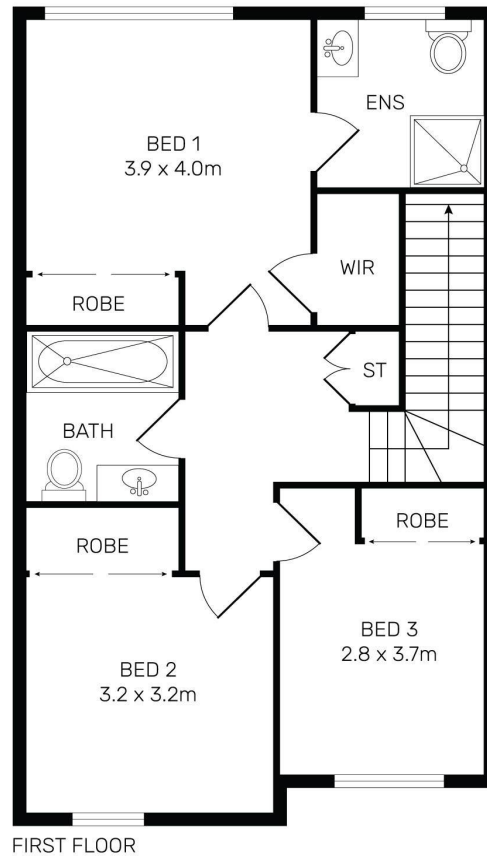
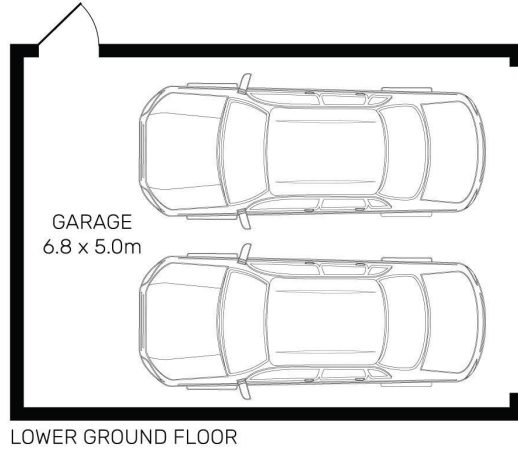
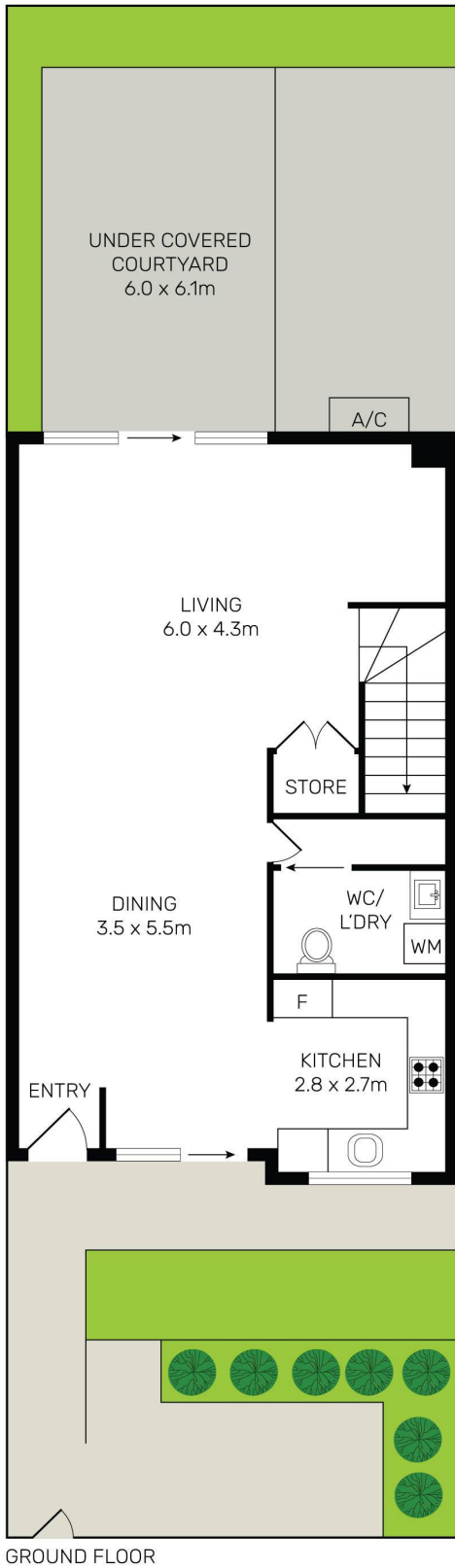

All information contained herein is gathered from all sources we believe to be reliable. However we cannot guarantee its accuracy and interested parties should rely on their own enquiries.



4/17 Adah Street, Guildford

All information contained therein is gathered from relevant third parties sources. We cannot guarantee or give any warranty about the information provided. Interested parties must rely solely on their own enquiries.

